

ID SERIES DATASHEET Mar 01, 2005

ID-2 / ID-12 / ID-20

The ID2, ID12 and ID20 are similar to the obsolete ID0, ID10 and ID15 MK(ii) series devices, but they have extra pins that allow Magnetic Emulation output to be included in the functionality. The ID-12 and ID-20 come with internal antennas, and have read ranges of 12+ cm and 16+ cm, respectively. With an external antenna, the ID-2 can deliver read ranges of up to 25 cm. All three readers support ASCII, Wiegand26 and Magnetic ABA Track2 data formats.



ID2 / ID12 / ID20 PIN-OUT

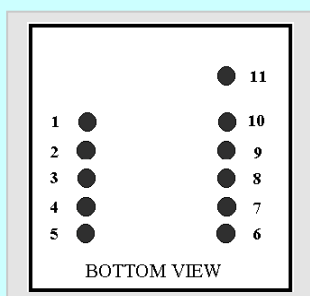

1. GND
2. RES (Reset Bar)
3. ANT (Antenna)
4. ANT (Antenna)
5. CP
6. Future
7. +/- (Format Selector)
8. D1 (Data Pin 1)
9. D0 (Data Pin 0)
10. LED (LED / Beeper)
11. +5V

Operational and Physical Characteristics

Parameters	ID-2	ID-12	ID-20
Read Range	N/A (no internal antenna)	12+ cm	16+ cm
Dimensions	21 mm x 19 mm x 6 mm	26 mm x 25 mm x 7 mm	40 mm x 40 mm x 9 mm
Frequency	125 kHz	125 kHz	125 kHz
Card Format	EM 4001 or compatible	EM 4001 or compatible	EM 4001 or compatible
Encoding	Manchester 64-bit, modulus 64	Manchester 64-bit, modulus 64	Manchester 64-bit, modulus 64
Power Requirement	5 VDC @ 13mA nominal	5 VDC @ 30mA nominal	5 VDC @ 65mA nominal
I/O Output Current	+/-200mA PK	-	-
Voltage Supply Range	+4.6V through +5.4V	+4.6V through +5.4V	+4.6V through +5.4V

Pin Description & Output Data Formats

Pin No.	Description	ASCII	Magnet Emulation	Wiegand26
Pin 1	Zero Volts and Tuning Capacitor Ground	GND 0V	GND 0V	GND 0V
Pin 2	Strap to +5V	Reset Bar	Reset Bar	Reset Bar
Pin 3	To External Antenna and Tuning Capacitor	Antenna	Antenna	Antenna
Pin 4	To External Antenna	Antenna	Antenna	Antenna
Pin 5	Card Present	No function	Card Present *	No function
Pin 6	Future	Future	Future	Future
Pin 7	Format Selector (+/-)	Strap to GND	Strap to Pin 10	Strap to +5V
Pin 8	Data 1	CMOS	Clock *	One Output *
Pin 9	Data 0	TTL Data (inverted)	Data *	Zero Output *
Pin 10	3.1 kHz Logic	Beeper / LED	Beeper / LED	Beeper / LED
Pin 11	DC Voltage Supply	+5V	+5V	+5V

* Requires 4K7 Pull-up resistor to +5V

ID Innovations

Advanced Digital Reader Technology

----Better by Design

Circuit Diagram for the ID2

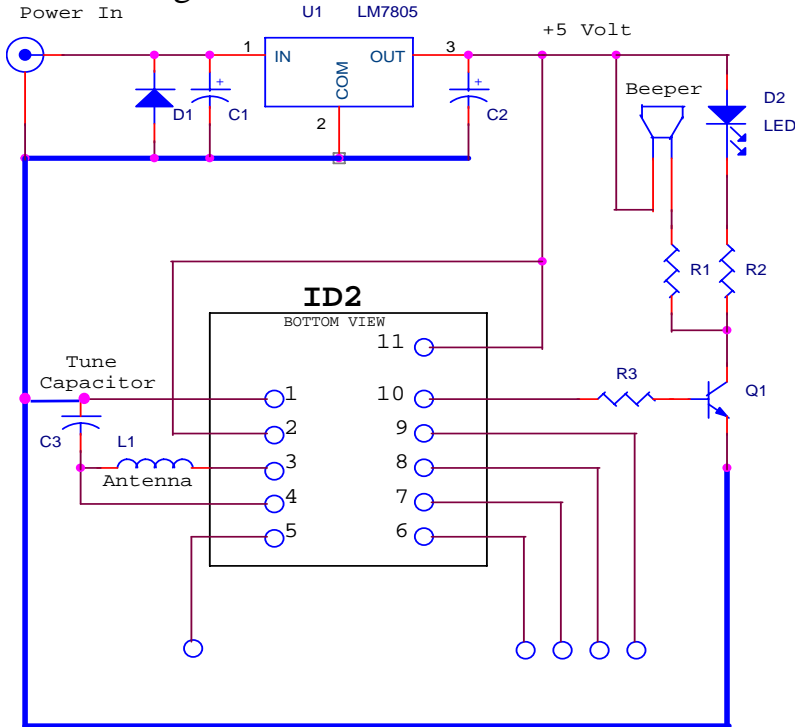

COMPONENT LIST

R1 = 100R
 R2 = 1K
 R3 = 1K
 C1 = 100uF 16V
 C2 = 100uF 10V
 C3 = 1nF COG 100V *
 Beeper = 2.7-3.5KHz 100R
 D1 = 1N4001
 D2 = GREEN LED
 U1 = LM7805
 Q1 = UTC8050 (NPN)
 L1 = 640Uh

ID2 = ID Innovations ID2

* Please Note the ID2 has an internal tuning capacitor of 1.5nF and this makes the total tuning capacity = 2.5nF

The 3.1Khz Beeper Logic is centered for most Beepers in range 2.7-3.5Khz

Circuit Diagram for the ID-12/ID20

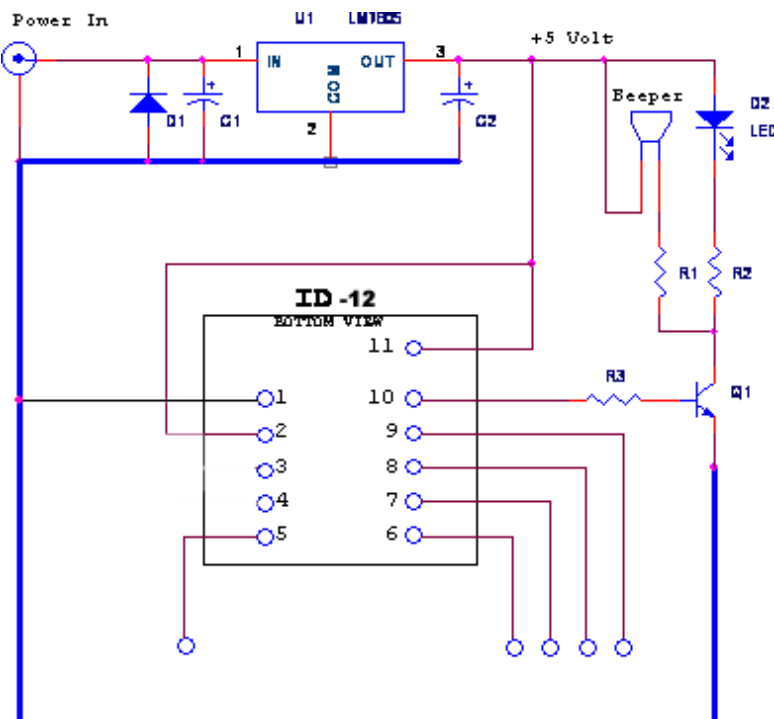

COMPONENT LIST

R1 = 100R
 R2 = 1K
 R3 = 1K
 C1 = 100uF 16V
 C2 = 100uF 10V
 Beeper = 2.7-3.5KHz 100R
 D1 = 1N4001
 D2 = GREEN LED
 U1 = LM7805
 Q1 = UTC8050 (NPN)
 ID2 = ID Innovations ID2

* Please Note the ID2 has an internal tuning capacitor of 1.5nF and this makes the total tuning capacity = 2.5nF

The 3.1Khz Beeper Logic is centered for most Beepers in range 2.7-3.5Khz

ID Innovations

Advanced Digital Reader Technology

----Better by Design

ID-2RW, ID-12RW Brief Data

The ID2-RW, ID12-RW and ID15-RW are a new series of Read/Write modules for the Temec Q5 tag. It has full functionality including password. They contain built-in algorithms to assist customers programming the popular Sokymat Unique type tag. Password protection is allowed. Control is via a host computer using a simple terminal program such as hyper terminal or Qmodem.



ID2 / ID12 / ID20 PIN-OUT

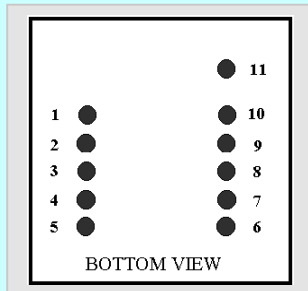

- | | |
|----|---------------------|
| 1 | GND |
| 2 | RES (Reset Bar) |
| 3 | ANT (Antenna) |
| 4 | ANT (Antenna) |
| 5 | Future |
| 6 | Program LED |
| 7 | ASCII in |
| 8 | Future |
| 9 | ASCII Out |
| 10 | Read (LED / Beeper) |
| 11 | +5V |

Operational and Physical Characteristics

Parameters	ID-2RW	ID-12RW	ID-20RW
Read Range	N/A (no internal antenna)	12+ cm (Unique Format)	15+ cm (Unique Format)
Dimensions	21 mm x 19 mm x 6 mm	26 mm x 25 mm x 7 mm	40 mm x 40 mm x 9 mm
Frequency	125 kHz	125 kHz	125 kHz
Card Format	Temec Q5555	Temec Q5555	Temec Q5555
Read Encoding	Manchester modulus 64	Manchester modulus 64	Manchester modulus 64
Power Requirement	5 VDC @ 13mA nominal	5 VDC @ 30mA nominal	5 VDC @ 50mA nominal
I/O Output Current	+/-200mA PK	-	-
Voltage Supply Range	+4.6V through +5.4V	+4.6V through +5.4V	+4.6V through +5.4V
Coil Detail	L = 0.6mH - 1.5mH, Q = 15-30	-	-

Description

A host computer is required to send the commands to the module. A simple terminal program such as Qmodem or Hyper-terminal can be used to send commands to the module. The blocks are individually programmable. If you have ever found that the Q5 can be a bit 'Twitchy' to program this programmer module is your solution. The command interface is simple to use and easily understood. The programmer also has two types of internal reader. One of these is provided to read Sokymat 'Unique' type tag configuration.

Magnetic Timing Diagram

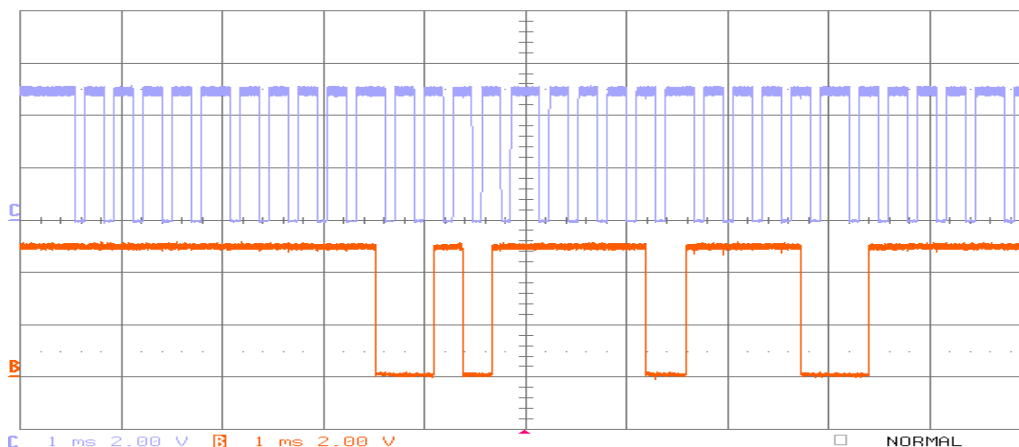

DATA FORMATS

Output Data Structure – ASCII

STX (02h)	DATA (10 ASCII)	CHECK SUM (2 ASCII)	CR	LF	ETX (03h)
-----------	-----------------	---------------------	----	----	-----------

[The 1byte (2 ASCII characters) Check sum is the “Exclusive OR” of the 5 hex bytes (10 ASCII) Data characters.]

Output Data Structure – Wiegand26

1	2	3	4	5	6	7	8	9	10	11	12	13	14	15	16	17	18	19	20	21	22	23	24	25	26	
P	E	E	E	E	E	E	E	E	E	E	E	E	O	O	O	O	O	O	O	O	O	O	O	O	O	P
Even parity (E)													Odd parity (O)													

P = Parity start bit and stop bit

Output Data Magnetic ABA Track2

10 Leading Zeros	SS	Data	ES	LCR	10 Ending Zeros
------------------	----	------	----	-----	-----------------

[SS is the Start Character of 11010, ES is the end character of 11111, LRC is the Longitudinal Redundancy Check.]

Dimensions (Top View) (mm)

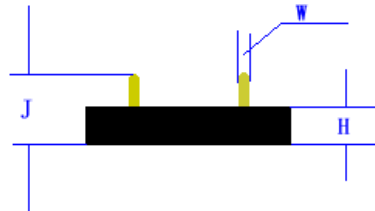
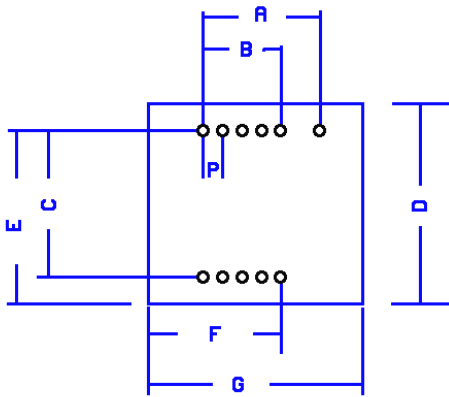

	ID-2			ID-12			ID-20		
	Nom.	Min.	Max.	Nom.	Min.	Max.	Nom.	Min.	Max.
A	12.0	11.6	12.4	12.0	11.6	12.4	12.0	11.6	12.4
B	8.0	7.6	8.4	8.0	7.6	8.4	8.0	7.6	8.4
C	15.0	14.6	15.4	15.0	14.6	15.4	15.0	14.6	15.4
D	20.5	20.0	21.5	25.3	24.9	25.9	40.3	40.0	41.0
E	18.5	18.0	19.2	20.3	19.8	20.9	27.8	27.5	28.5
F	14.0	13.0	14.8	16.3	15.8	16.9	22.2	21.9	23.1
G	22.0	21.6	22.4	26.4	26.1	27.1	38.5	38.2	39.2
P	2.0	1.8	2.2	2.0	1.8	2.2	2.0	1.8	2.2
H	5.92	5.85	6.6	6.0	5.8	6.6	6.8	6.7	7.0
J	9.85	9.0	10.5	9.9	9.40	10.5	9.85	9.4	10.6
W	0.66	0.62	0.67	0.66	0.62	0.67	0.66	0.62	0.67

Note – measurements do not include any burring of edges.

NOTICE - Innovated Devices reserve the right to change these specifications without prior notice.

Designing Coils for ID2

The recommended Inductance is 1.08mH to be used with an internal tuning capacitor of 1n5. In general the bigger the antenna the better, provided the reader is generating enough field strength to excite the tag. The ID-2 is relatively low power so a maximum coil size of 15x15cm is recommended if it is intended to read ISO cards. If the reader is intended to read glass tags the maximum coil size should be smaller, say 10x10cm.

There is a science to determine the exact size of an antenna but there are so many variables that in general it is best to get a general idea after which a degree of 'Try it and see' is unavoidable.

If the reader is located in a position where there is a lot of heavy interference then less range cannot be avoided. In this situation the coil should be made smaller to increase the field strength and coupling.

It is difficult to give actual examples of coils for hand winding because the closeness and tightness of the winding will significantly change the inductance. A professionally wound coil will have much more inductance than a similar hand wound coil.

For those who want a starting point into practical antenna winding it was found that 63 turns on a 120mm diameter former gave an inductance of 1.08mH. For those contemplating adding an additional tuning capacitor it was found that 50 turns on a 120mm diameter former gave 700uH. The wire diameter is not important.

Anybody who wishes to be more theoretical we recommend a trip to the Microchip Website where we found an application sheet for Loop Antennas. <http://ww1.microchip.com/downloads/en/AppNotes/00831b.pdf>

The Tuning Capacitor

It is recommended that the internal 1n5 capacitor is used for tuning, however a capacitor may be also be added externally. The combined capacitance should not exceed 2n7. Do not forget that the choice of tuning capacitor can also substantially affect the quality of your system. The Id12 is basically an ID2 with an internal antenna. The loss in an ID12 series antenna is required to be fairly high to limit the series current. A low Q will hide a lot of the shortcomings of the capacitor, but for quality and reliability and repeatability the following capacitors are recommend.

Polypropylene	Good Readily available. Ensure AC voltage at 125kHz is sufficient.
COG/NPO	Excellent. Best Choice
Silver Mica	Excellent but expensive
Polycarbonate	Good Readily available. Ensure AC voltage at 125kHz is sufficient.

Voltage Working.

A capacitor capable of withstanding the RMS voltage at 125KHz MUST be chosen. The working voltage will depend on the coil design. I suggest the designer start with rugged 1n5 Polypropylene 630v capacitor to do his experiments and the come down to a suitable size/value. The capacitor manufacturer will supply information on their capacitors. Do not simply go by the DC voltage. This means little. A tolerance of 2% is preferable. A tolerance of 5% is acceptable.

Fine Tuning

We recommend using an oscilloscope for fine-tuning. Connect the oscilloscope to observe the 125KHz AC voltage across the coil. Get a sizeable piece of ferrite and bring it up to the antenna loop. If the voltage increases then you need more inductance (or more capacitance). If the voltage decreases as you bring the ferrite up to the antenna then the inductance is too great. If you have no ferrite then a piece of aluminum sheet may be used for testing in a slightly different way. Opposing currents will flow in the aluminum and it will act as a negative inductance. If the 125kH AC voltage increases as the aluminum sheet approaches the antenna then the inductance is too high. Note it may be possible that the voltage will first maximize then decrease. This simply means that you are near optimum tuning. If you are using ferrite then the coil is a little under value and if you are using an aluminum sheet then the coil is a over under value.

ID Innovations

Advanced Digital Reader Technology

----*Better by Design*