

MIFARE SMARTCARD READER DEVELOPMENT SYSTEM



local focus _ global reach
adilam
Technologies

Mifare Smartcard Reader Development Board

RFID Overview:

Most RFID (Radio Frequency Identification) applications consist of only a transceiver (also referred to as an interrogator or reader), a transponder (RF Tag) with a unique serial number and an antenna.

The transceiver emits a radio frequency signal that is captured by the antenna and energizes a small IC mounted inside the RF Tag. The tag's unique serial number, retrieved from the EPROM or ROM, is transmitted back to the transceiver. This simple exchange of information over a wireless link is the basis of all RFID projects.

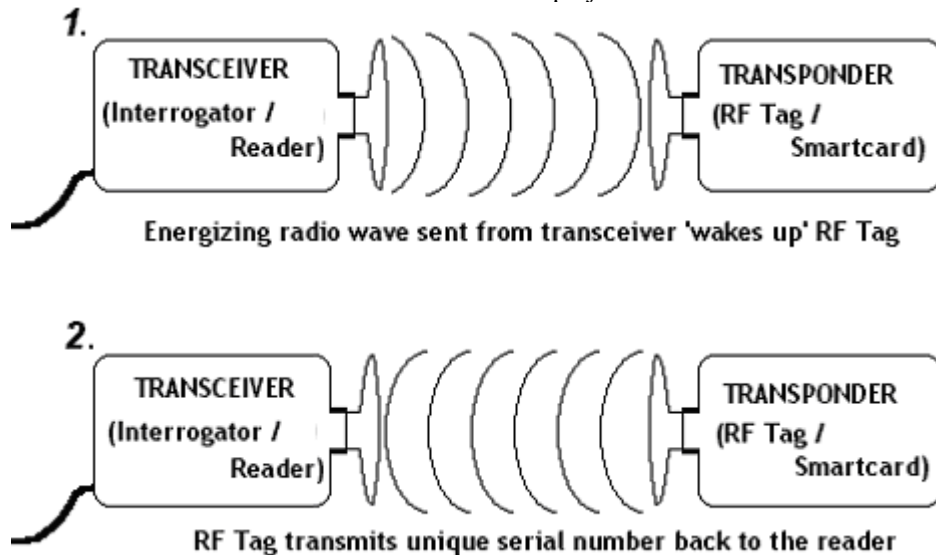

The real excitement of RFID comes from the number of applications that designers have incorporated the technology into. Libraries, toll ways, animal identification, keyless entry points and supply logistics are all common uses of RFID. Although, imagine loading your trolley at the supermarket and walking straight out the door, imagine if cars applied their own brakes at red lights, imagine if certain doors only opened for certain people. With all these applications currently being tested or in use, it's easy to understand why expertise in RFID technology is becoming a valuable tool.

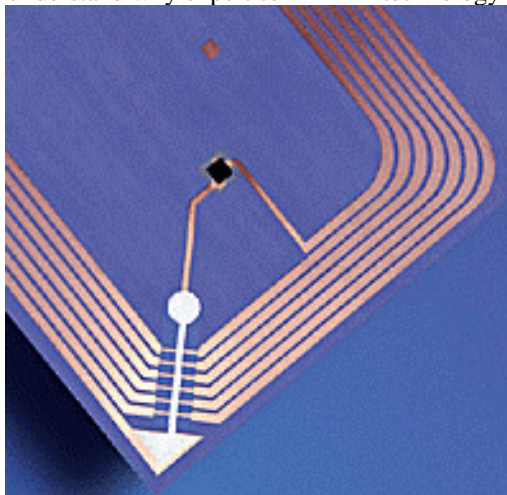

Example of 13.56MHz paper tag with copper foil antenna with IC (black square in centre).

RFID Technology:

RFID systems operate at many different frequencies throughout the 'Industrial, Scientific and Medical' (ISM) bands of the frequency spectrum. Commonly used frequencies are 125Khz to 148Khz (LF = Low Frequency), 13.56Mhz (HF = High Frequency), 850Mhz to 950Mhz and 2.4Ghz to 2.5Ghz (UHF = Ultra High Frequency). The particular frequency chosen may have certain RF characteristics that other bands don't.

The 125Khz to 148Khz band was the first utilized by RFID technology and is still used today for access control, security, animal identification, manufacturing applications and warehouse logistics.

Whilst no RFID tag can be read directly through metal, the low frequency range of RFID is the most adaptable to a metallic environment. Low frequency RFID tags will exhibit only a slight loss of

Mifare Smartcard Reader Development Board

performance when embedded or mounted on metallic surface. The low frequency carrier limits data transmission to typical speeds of 2k to 8k Baud.

During the late 1990's, 13.56Mhz was widely used, this higher frequency allowed for a longer read range and a smaller antenna. Antennas for this range can be made from circuit board tracks or conductive ink printed on to a paper like substrate. 13.56Mhz is commonly used in library books, laundry identification, access control and original equipment manufacture (OEM) applications.



Long range RFID, covering read ranges of 1 meter to over 10 meters, is generally reserved for microwave frequencies, 850Mhz to 950Mhz, 2.4Ghz to 2.5Ghz and 5.8Ghz. RFID systems operating at these frequencies are used in highway toll tags, identification of private vehicle fleets and asset tracking.

RFID tags operating at microwave frequencies will exhibit decreased read ranges when exposed to metal or water as these materials absorb high frequency waves, a common deficiency in all high frequency radio communications. This decreased read range is also present in tags placed on or near the human body as our bodies are over two-thirds water. Although, limitations due to metallic or liquid environments has in part been concurred with new designs of 'environmental' UHF RFID tags.

There are a few UHF and microwave RFID Tags / Transponders referred to as "active" tags as they normally contain an in-built battery that supplies sufficient power for the EPROM, data transmission and memory retention. Active tags normally exhibit an operating life of around two to five years whilst a passive tag (containing no battery) has a theoretically endless operating life.

As well as active or passive, tags (transponders) are further classified in terms of either read only or read / write. Read only tags contain a small ROM that once energized transmits a unique serial number. Read / write tags, commonly called contact-less smart cards, can be read by transceivers but also have data written to them. For this reason read / write tags with encryption are used in funds transactions as they allow data values to be stored directly on to them. A data block containing monetary values on an RFID transponder is referred to as a purse. Encryption of the monetary values saved in the purse is included as part of the RFID technology.

Certain RFID tags employ a system known as anti-collision which enables multiple tags to be read within the one energizing field. Several anti-collision techniques exist in modern RFID systems.

MIFARE Smartcard Reader Development System Introduction:

We will focus on the 13.56MHz smart card standard, Philips Mifare and the ID-20MF Mifare reader development kit.

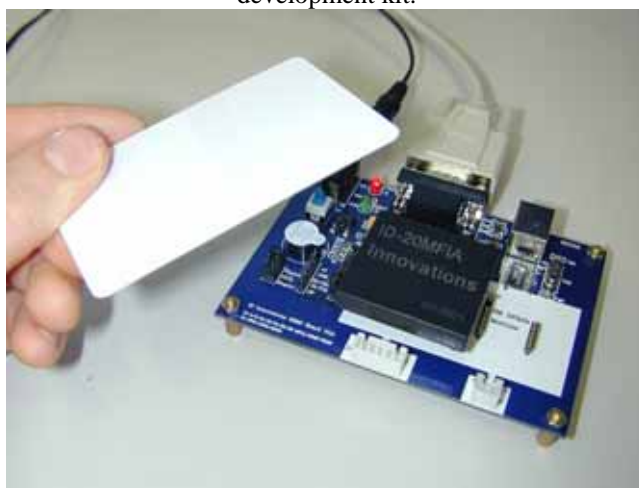

A recently released smartcard development board for MIFARE (a smart card brand name of Philips under which they manufacture RFID tags and readers) gives a "hands on" approach to RFID technology. The development board is powered and interfaced to a PC via USB or a serial port with an external power supply. Supplied software allows users to read tag serial numbers, read individual data blocks, write values to a purse and also increment or decrement those same purse values by various amounts.

The MIFARE Smartcard Reader Development System demonstrates the technology applied in highway toll systems, security access control, transport ticketing systems and novelty money purse cards (often available within large theme parks).

The board operates at the 13.56Mhz frequency using the MIFARE transceiver module, ID-20MFIA. The IA in the model number refers to this transceiver containing an internal antenna; other

Mifare Smartcard Reader Development Board

transceivers such as the ID-20MFWA are manufactured without an antenna. Operation of any WA transceiver requires the design of a suitable antenna for use with the specified operating frequency.

The ID-20MF transceiver used on the development board incorporates a 'reader talks first system' (RTF). In an RTF system the 13.56MHz link is constantly open but a response is only received after a request for data has been sent. Other systems may employ Transponder Talks First (TTF) where the tag continuously sends out a serial number as soon as it is energized in the field; no direct request for data is sent to the card.

ID-20MFWR MIFARE Smartcard Reader Module:

The ID-20MF modules allow designers to quickly and efficiently develop smart card readers and reader terminals without complex protocols and tricky RF design.

A typical application block diagram is shown below.

SERIAL PC CONNECTION

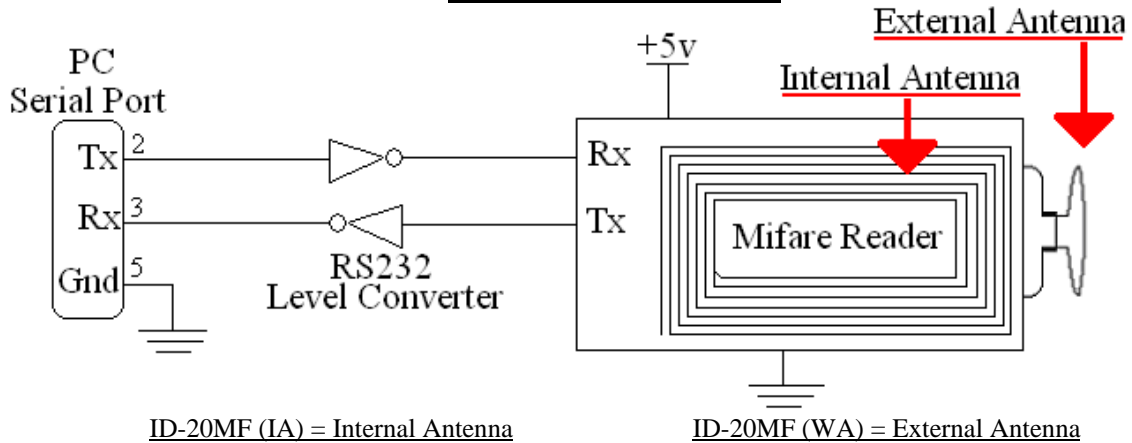

MICRO CONTROLLER

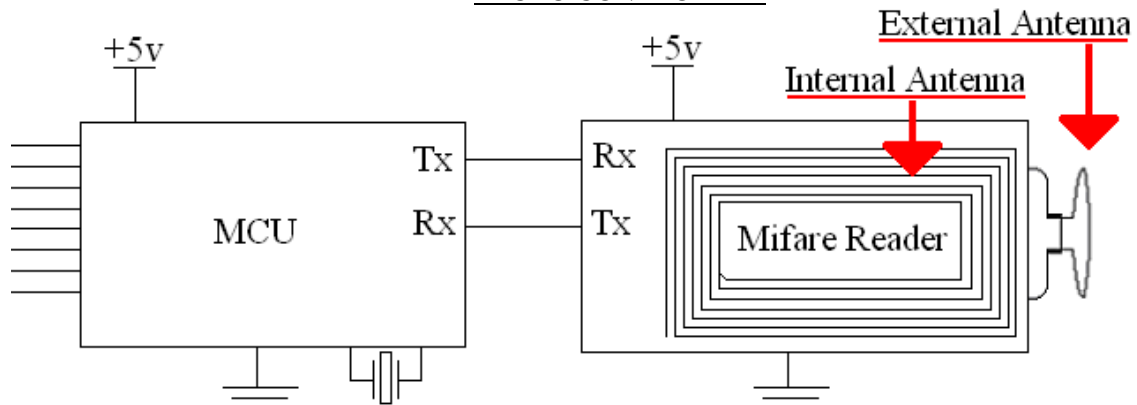

UART commands and simple protocols are defined in the ID-20MF user manual.



Mifare Smartcard Reader Development Board

Contact-Less Smart Card Varieties:

The development board will adequately read any MIFARE tags that operate at the frequency of 13.56Mhz. MIFARE tags available at this frequency can come in the form of credit cards, key fobs and small round discs. A Mifare 1kbyte (MFIS50) card is supplied with the development board.



There are 3 popular Mifare types; the MF1 IC S50 is MIFARE's standard card and contains 1kbyte of read / write non-volatile memory. The card has a data transfer rate of 106kbit per second and can be written to approximately 100,000 times. The 1kbyte of memory available on the MC1 IC S50 is arranged into 16 sectors, each sector containing 4 blocks of 16 bytes (16 sectors x 4 blocks x 16 bytes = 1024 bytes of total memory, 1kbyte). The allocation of memory can be seen in Figure 1 (16 sectors by 4 blocks) as the MF1 IC S50 tab is selected.

Each sector of the MF1 IC S50's memory contains one password protection block. This is assigned as the fourth block in each sector. The first three bytes of block 3 are 'Key A', the next two bytes are a control section and the final three bytes are 'Key B'. The password protection feature allows only certain users to access specific programming functions on the card. For example, a person with Key A may be able to deduct money from the card but only an authorized person with Key B can write money to the card. This function is employed in highway toll systems, a user deducts money every time they use the highway and only an authorised person can replenish the monetary value on the card. The control section can be written to, to allocate different read / write settings depending on which key a user possesses. It is recommended that for general purpose use Key A, Key B and the control bits are not altered as this may lock the card for use.

The MF1 IC S70 is also referred to as a standard card and exhibits all the same physical and electrical characteristics as the MF1 IC S50, but contains 4kbyte of memory. The memory is arranged as 32 sectors each containing 4 blocks and another 8 sectors each containing 16 blocks (32 sectors x 4 blocks + 8 sectors x 16 blocks = 256). All 256 sectors contain 16 bytes of memory (256 sectors x 16 bytes = 4096 bytes of total memory, 4kbyte).

The MF0 IC U1 "Ultralite" was designed as part of a ticketing system for transport services. It contains 512 bits of memory arranged as 16 pages with 4 bytes to each page, each byte containing 8 bits (16 pages x 4 bytes per page x 8 bits = 512 bits of memory). There are 384 read / write user bits.

For more information on Mifare cards please contact Adilam Technologies on:
(03) 9737 4900 (www.adilamtech.com.au).



Instruction of the ID-20MF Demo Kit:

The demonstration kit can be connected to either the serial port or the USB port of the PC, but not both at the same time.

Mifare Smartcard Reader Development Board

Serial Connection:

Serial is easiest to apply because there is no installation of the USB software required, but a 9V DC adaptor is required.

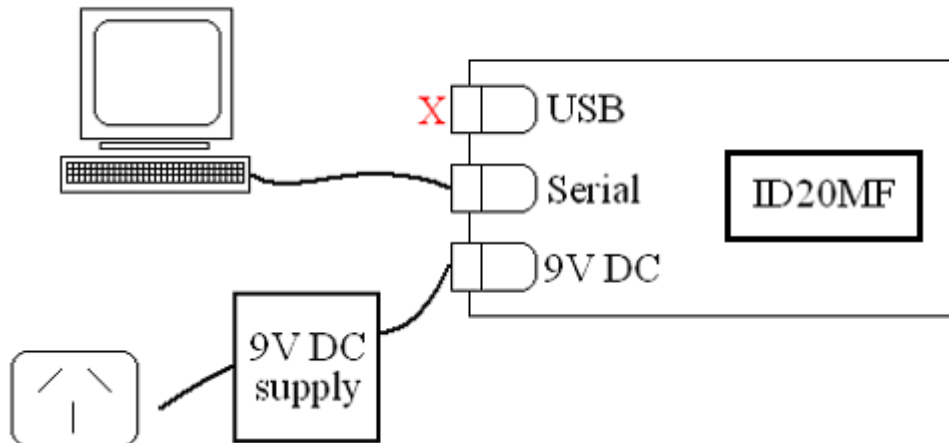

USB Connection:

- **Please install the USB software CD Drivers first before connecting the ID-20MF demo kit to the PC.**

After software installation, use the 'control panel' and 'system info' to find which serial port the software has been installed too. You'll need to remember this COM port number when you launch the software package.

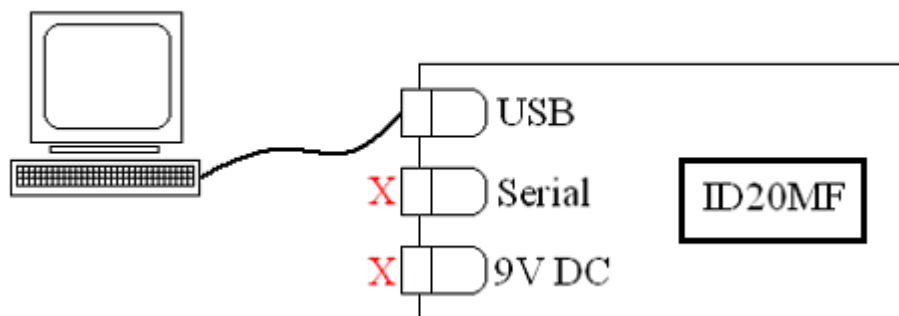

MIFARE Smart Car Reader Development System Operation:

Place one of the supplied cards on top of the ID-20MF module on the board. Select from the drop down menu your appropriate USB COM port or serial COM port and then click on the option "Link". The screen will return the message "System Link Success". System link advises if there is a connection between the PC and the reader kit. If you experience trouble linking to the kit ensure that the USB cable or serial cable is connected properly to the computer and to the board, the MIFARE card is in the correct position (it should be sitting on top or situated close to the MF-20 module) and that you have selected the correct com port.

Mifare Smartcard Reader Development Board

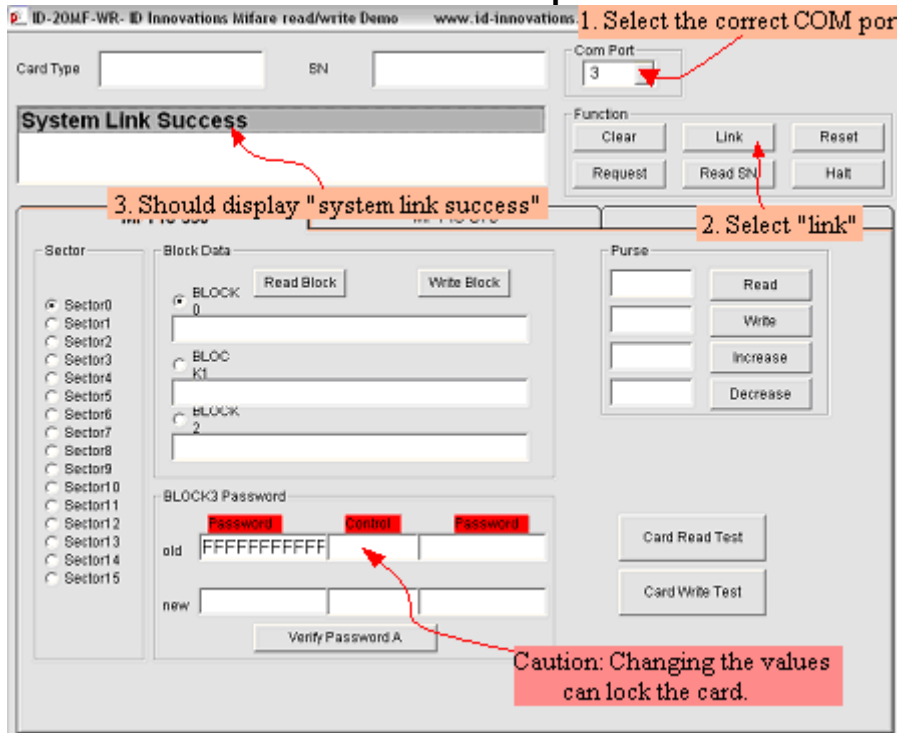

Figure 1: System Link Success

Once you have successfully established a link between the card and the board you can select 'Request'. This will return a number indicating the type of MIFARE card being used. Most standard MIFARE cards look physically similar; requesting the card type through a software command is the easiest way to identify different card types.

Figure 2 shows the message "Read card type Success" and a returned card value of 0400 that corresponds to the MF1 IC S50 card. In the software program select the 'tab' of the card you are using, either MF1 IC S50, MF1 IC S70 or MF0 IC U1.

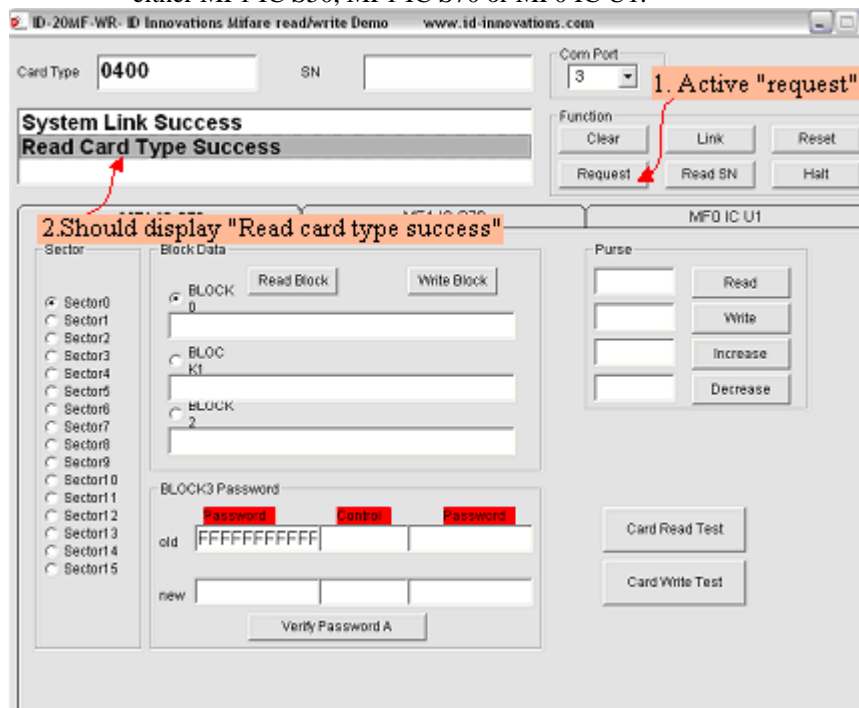

Figure 2: Read Card Type Success

Other values the system may return, along with the corresponding card types are listed below.

Details on all cards listed below can be obtained from <http://mifare.net/>

Return Value	Card Type
4400	Ultra Light
0400	Mifare One (S50)
0200	Mifare One (S70)

Mifare Smartcard Reader Development Board

By clicking on the option “Read SN” you will be able to read the cards unique serial number, see Figure 3. The screen should display the cards serial number and return the message “Read SN Success”.

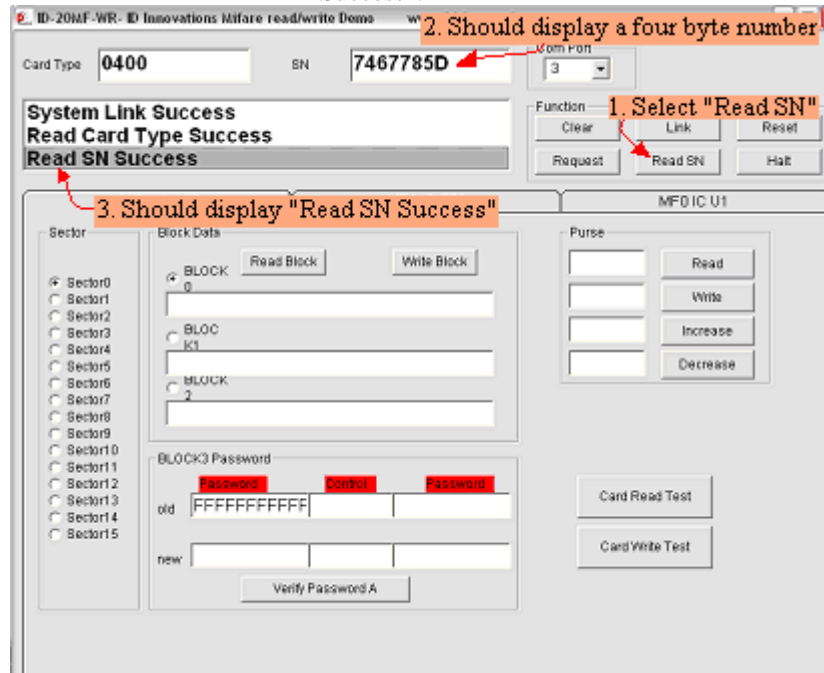

Figure 3: Read SN Success

By clicking on “Read Block” the sector and block you have selected will be read and the software will display a returned value 16 bytes long. The 16 bytes are displayed in 32 hex numbers, each hex number corresponding to one nibble of data. The message “Read Block Data Success” should also be returned. See Figure 4. A user can select different blocks and different sectors to read from but also perform a read test by clicking on “Card Read Test”; this command will read the entire cards memory.

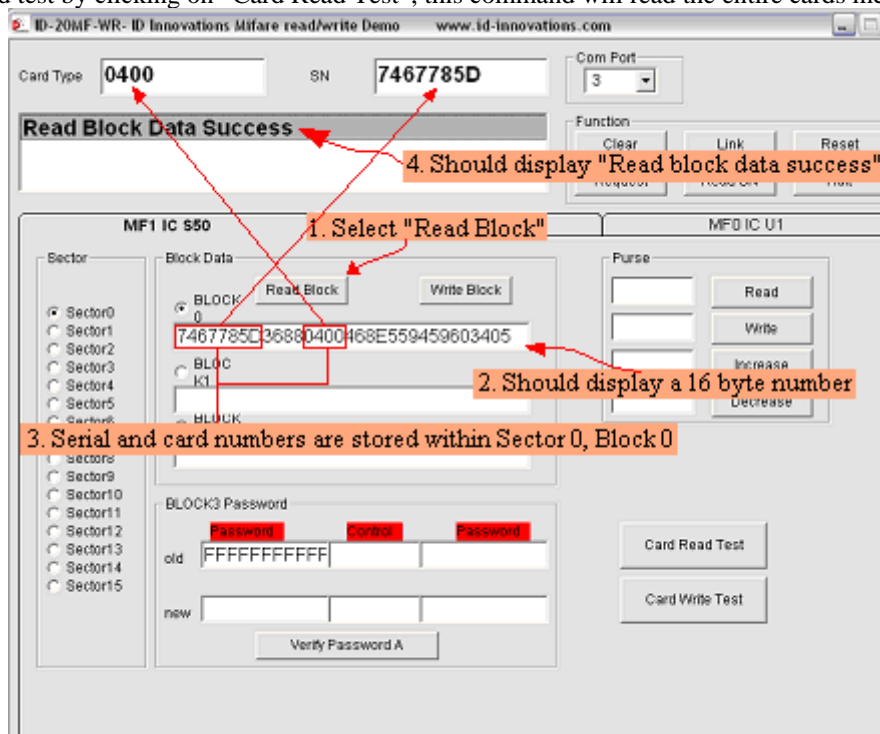

Figure 4: Read Block Data Success

To write data to a specific memory location select the sector and block you wish to write to, Figure 5 shows Sector 6 and block 0 selected. Highlight and delete any redundant data displayed in the text field or if the text field is clear, place your Windows cursor into the field you’ll be manipulating (note: the text field will only be clear if you have not done a read since turning on the program). See Figure 5.

Mifare Smartcard Reader Development Board

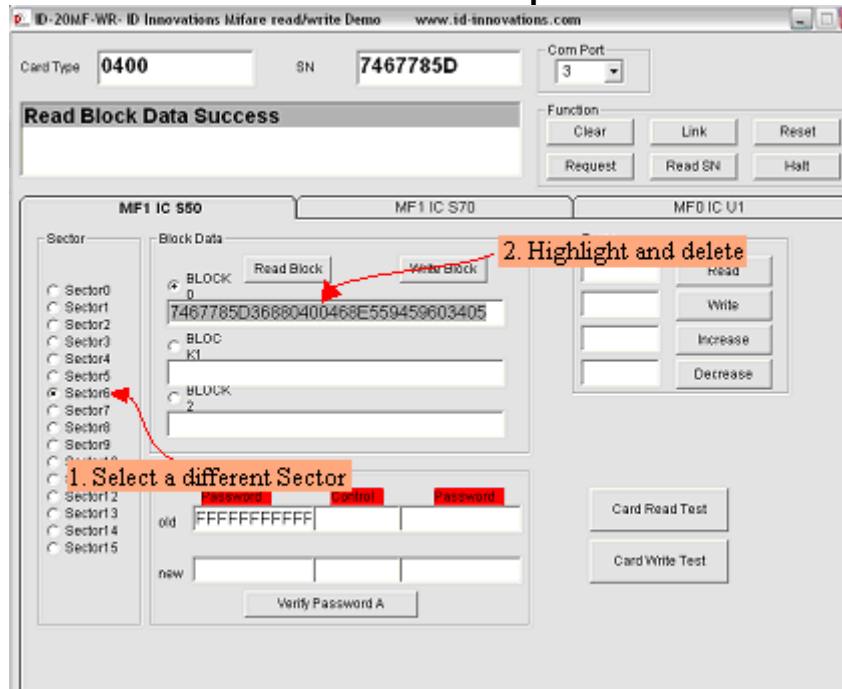

Figure 5: Highlight and delete redundant data

Press 'Backspace' to delete the redundant data and then type new data in the standard hex format. Figure 6 shows a data entry of 0F3391B01011AD11F002567A1B001A7E. By clicking 'Write Block' the message "Write Block Data Success" will be displayed, see Figure 6. This message indicates that the data has been sent to the MIFARE card and has been successfully stored.

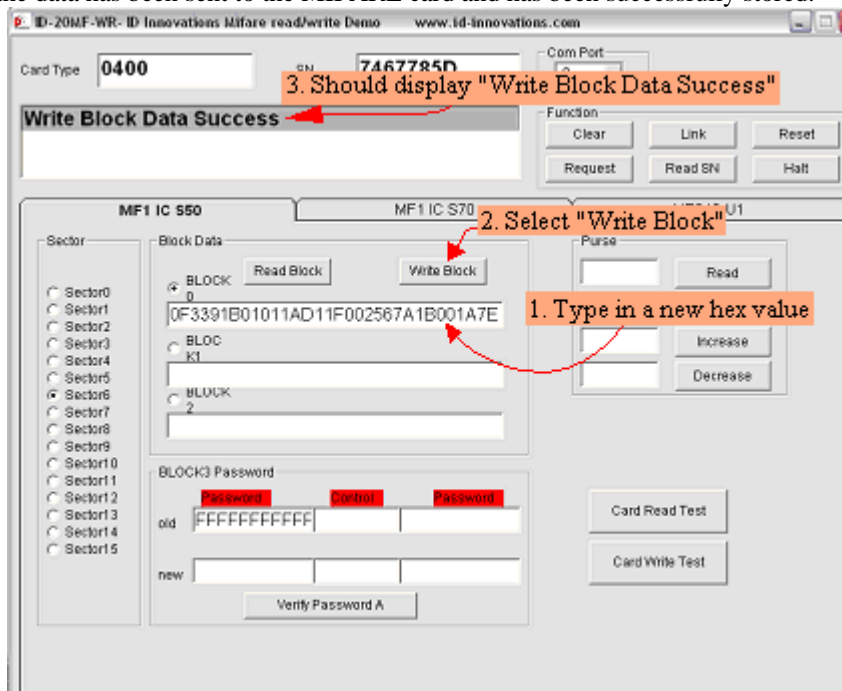

Figure 6: Write Block Data Success

To ensure that your data was successfully written to the appropriate block you can click on "Read Block". This will return the message "Read Block Data Success" and display the written data in the appropriate block. See Figure 7.

Mifare Smartcard Reader Development Board

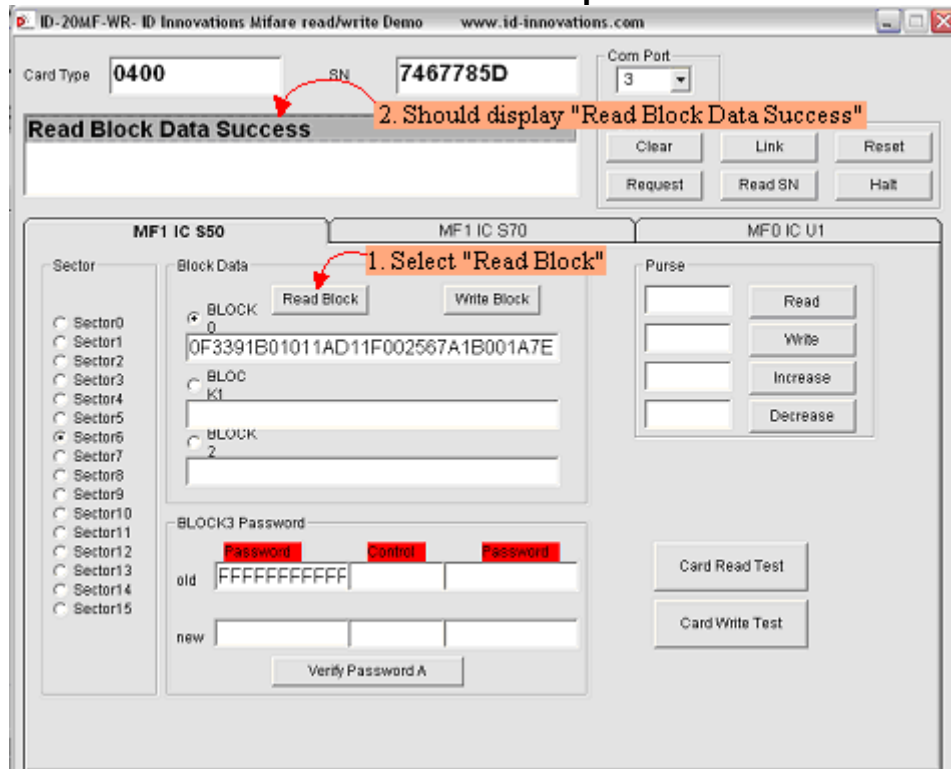

Figure 7: Read Block Data Success

In the same way that raw data is written to the card, data can also be saved as a monetary value in a purse. The location of a purse can be user selected, as the term 'purse' actually refers to any memory block on the card that contain monetary data. When writing to the purse the data is saved in the currently selected memory block. To write data to a purse enter a numerical amount under the heading "Purse", next to the button "Write". Figure 8 shows a value of 5 has been entered. By clicking "Write", this value is written to the purse and the "Write Purse Success" message is returned.

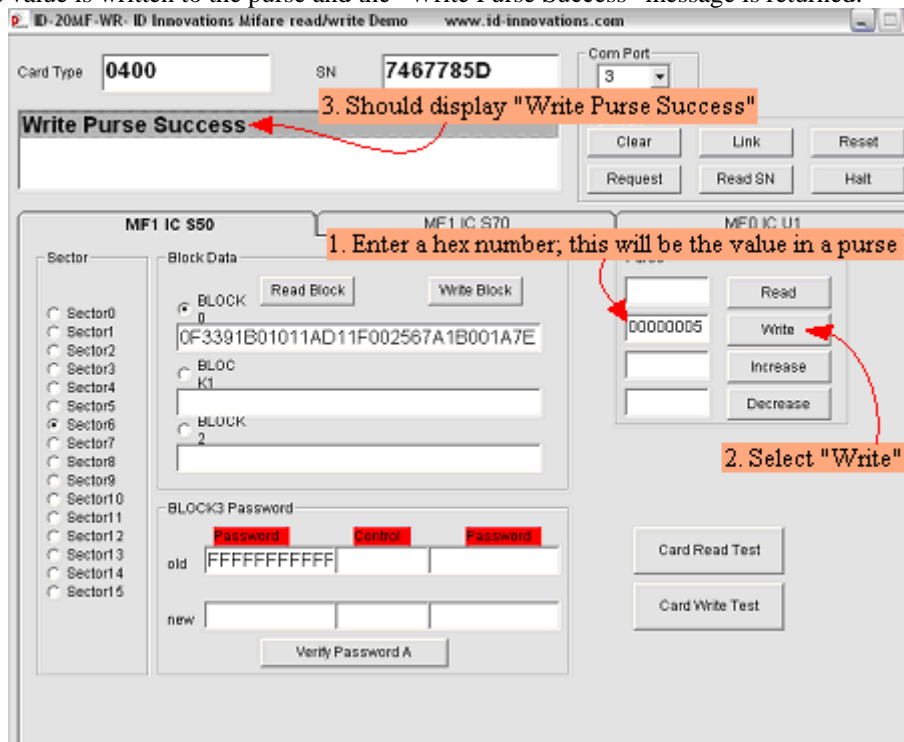

Figure 8: Write Purse Success

Values can then be read from the purse by simply clicking "Read". See Figure 9. This will return a purse value and the message "Read Purse Success".

Mifare Smartcard Reader Development Board

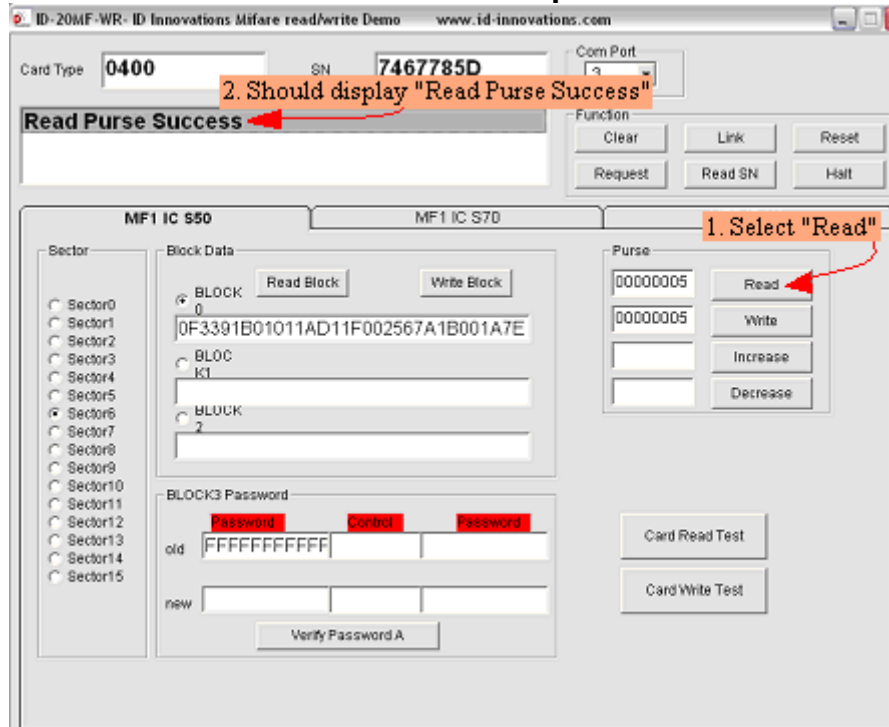

Figure 9: Read Purse Success

The purse value can be incremented by a user definable amount. This amount can be entered into the text field next to the button “Increase”. Figure 10 shows that the purse will be incremented by 5. Upon clicking “Increase” the message “Increment Purse Success” will be displayed. This indicates that the value stored in the purse was incremented by the amount entered.

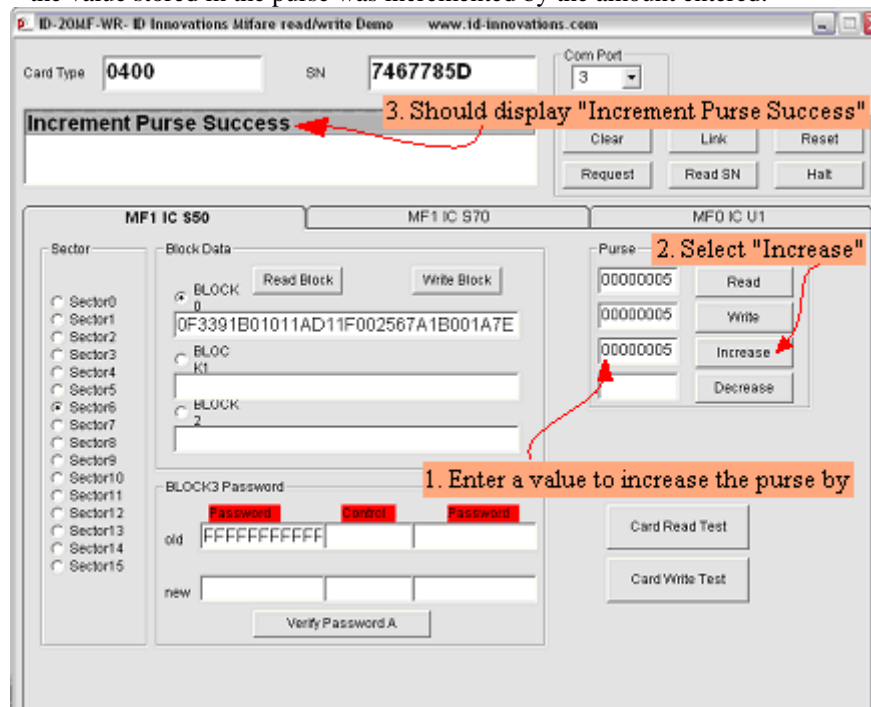

Figure 10: Increment Purse Success

By reading the purse again the value will have increased by the designated ‘increment’ amount. Figure 11 shows that the purse value has increased by 5 to a hex value of A (decimal value of ten).

Mifare Smartcard Reader Development Board

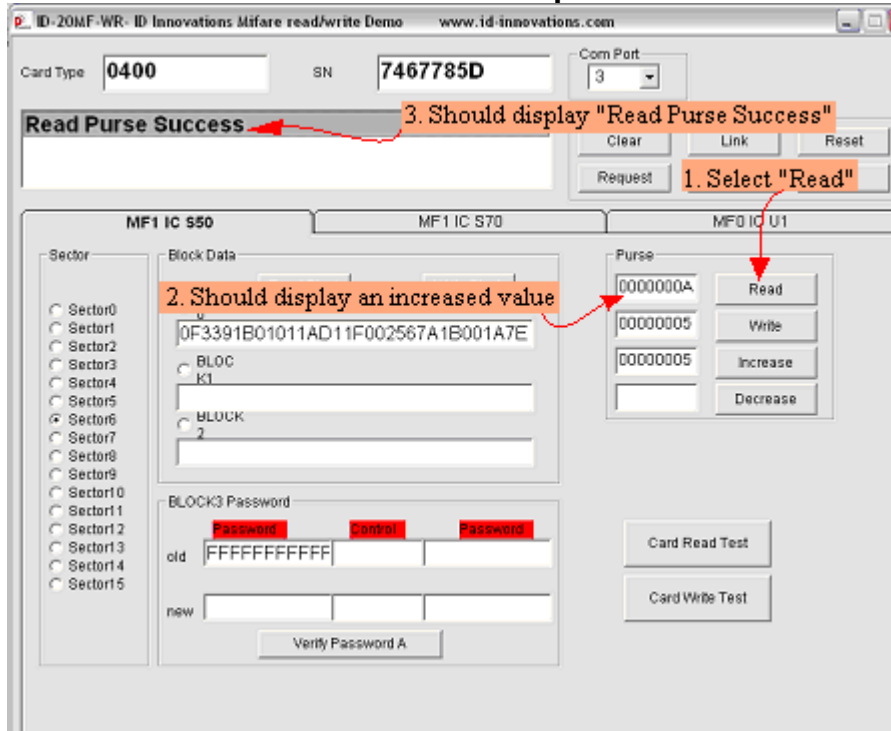

Figure 11: Read Purse Success

The MIFARE development board gives users a chance to become familiar with RFID, a technology that is being utilized in more applications everyday. The MIFARE development board gives users a “hands on” approach to RFID offering them the chance to read, write and understand many different card types. The MIFARE development board manual lists the command signals sent to the module to read serial numbers, purse values, card types, etc. This helpful knowledge will allow designers to easily implement RFID technology into their new designs. The MIFARE development board is available through Adilam Technologies.

www.adilamtech.com.au